



ST. LAWRENCE COUNTY
EMERGENCY MEDICAL SERVICES
ADVISORY BOARD

Minutes of the St. Lawrence County EMS Advisory Board
November 17, 2020

Meeting called to order by Chair Mark Deavers at 1910 hours, roll call taken and duly recorded.

Members Present: Nicholas Wildey, Carol Muench, Aaron Johnson, Storm Cilley, Doug Bohl, Mark Deavers, Chris Towler, Jonathan Mitchell. All attending via Zoom.

Ex Officio Members Present: Ann Smith, Jonathan Mitchell.

Members Excused: Jay Moore, James Blackburn, Kevin Wells, James Barr, Tammy Sykes

Members Absent: Christopher Velez, Donald Thompson, Dr. Coates, Chelsea Snyder Dennis, Rita Curran (Ex-Officio)

Guests: Colleen Gleeson, Dana McGuire.

September 29, 2020 Minutes were accepted as presented. Motion to approve by Carol Muench, Second by NickWildey. Carried by voice vote.

Office of Emergency Services Report: Jonathan Mitchell. Not presented. Promised to email.
Discussion of proposed new EMS dispatch response category protocols. After a short trial run, several agencies expressed a dislike for codes. This protocol aligns with current national standards versus local St. Lawrence County terminology. Education is needed to familiarize providers with the meaning of the codes. A longer trial period will be conducted at a later date. No action was taken.

The Office of Emergency Services will be looking to add a second volunteer EMS Coordinator. This will be mainly an administrative position. Would prefer someone from the Gouverneur area.

North Country EMS Program Agency / REMSCO / REMAC Report: Ann Smith.

A new 12 lead ECG protocol for Basic EMTs has been introduced.

Due to COVID resurgence, the regional CME skills requirement for the second half of 2020 have been waived. Agencies are encouraged to check these skills inhouse. Didactic requirements for the second half must be completed and reported. One half of the yearly requirement for all levels.

Agency CME Managers are asked to update their provider rosters with the Program Agency.

North Country is working with Central NY and SUNY Upstate on a stroke education initiative and video. The first 120 agencies to have 50% of their providers complete the class will receive a \$200 stipend.

The next regional meeting will be held in February, 2021. There will probably be a REMAC meeting prior to that to discuss RSI.

There will be a spring Basic EMT original and refresher class hosted by Potsdam Rescue and Clarkson University. This will probably be a hybrid class.

The next SEMAC meeting will be the 8th and 9th of December. More feedback is requested regarding the proposed Part 800 revisions, particularly the quantities of supplies required, and the cost vs. benefit of those quantities. Example - 6 chest seals per ambulance. How often are chest seals used, and how often do they expire unused?

Air Medical - Colleen Gleeson

Report is attached. There has been an increase in calls completed from 329 in 2019 to 373 in 2020.

COVID-19 - Dana McGuire. St. Lawrence County Public Health

Showed a slide presentation that was made to the County Legislators.

629 cases, 11 in the hospital, 108 active cases in isolation 10 days long, 515 completed isolation, 6 deaths since March. There has been a steep increase in the last month. No days with less than 10 cases. One day with 23 cases. Extra help has been called in due the large amount of contact tracing required. 250% increase from the highest week in the spring.

In the first 2 months, 3/20 - 5/20 there were 199 cases. There have been 211 in the last 2 weeks, Nov. 1 - 15, 2020. There have been more contacts per case, probably due to schools reopening. Not seeing high transmission rates in the schools. Transmission seems to be mostly within families. Predicting an increase in cases.

Ann Smith reports that Lewis County reports that there were many positive tests among asymptomatic people. In St Lawrence County since fall most positive test have been among those showing symptoms. Most common symptoms are a loss of taste or smell, and symptoms similar to a common cold.

EMS providers are reminded that surgical masks, at a minimum, are required whenever two people are together in the same compartment of the ambulance. N95 masks and eye protection when with patient in patient care compartment. If a patient tests positive and the provider was not wearing a N95 mask the provider will be quarantined. 9 -10 providers from one Jefferson County agency have been quarantined. The cost of N95 masks has increased from \$0.95 to \$5.00 a piece.

As opposed to the CDC list of symptoms, locally a general feeling of fatigue and listlessness is most prominent.

Both CPH and CHMC are requiring EMS personal to wear proper PPE and masks on both providers and patients. N95 masks on providers, and a surgical mask on patients. Cloth masks are not appropriate for health care providers.

There has been an up tick in cases among the Amish community. Not many have been tested. Providers are encouraged to treat all members of the Amish community as covid positive. It is best to assume that all patients are positive.

Upcoming Training

The Gouverneur EMT class has started. Didactic on line. Skills at various locations. It will be a learning experience.

A reminder that the NYSDOH Vital Signs Academy continues to be on line and free.

Committee Reports - None

Old Business

Jonathan Mitchell reported on development of the county mutual aid policy. There is a problem

with the dispatch mapping software. The policy is written. They are struggling with the implementation.

Bylaws/Membership

Carol Muench reported on the propose realignment of the seat categories on the board. The EMS advisory board is returning to 21 members. 1/3 must be EMS. There are two open consumer slots and one open at large spot.

There was a discussion on realigning consumer and at large slots with a goal of increasing the diversity of the board. Mark suggested leaving consumer slots for actual consumers. Questioned what to do with hospital slots. Leave the EMS slots at 7 or increase to 9? Storm prefers more EMS slots. Input from others is important, but the providers are the ones doing the job. There was a suggestion to change the administrator slot to an at large slot. There are currently 5 openings. It was decided to list 3 as at large slots and 2 as consumers.

Carol will bring a proposal to the next meeting. In the meantime, we are seeking input regarding the diversity issue of community vs. the EMS service.

New Business

Proposed Meeting dates for 2021 are as follows:

January 26, 2021

March 23, 2021

May 25, 2021

September 28, 2021

November 30, 2021

Motion to adjourn by Carol Muench, Second by Storm Cilley.

Meeting adjourned at 2030.

Discussion was held regarding proposed NYS Part 800 changes. No action taken.

Discussion was held regarding EMResource tracking. No action taken.

Discussion on EMS Academy Access. No action taken.

SEMSCO Report: Mark Deavers

The state cannot waive anything from Article 30 or Part 800.

Seeking comments for changes prior to next state meeting. Email comments to Mark Deavers or Ann Smith.

There are emergency regulations coming.

Certifications at all levels have been extended by one year by the Governor's executive order. It is unclear what will happen when the executive order expires.

Course Sponsor funding is being cut by 20%.

There are some scope of practice changes coming.

Amy Eisenhower in the New Program Administrator for the DOH EMS for Children Program.

Expect cuts to Medicaid funding after the first of the year.

Air Medical Report: Colleen Gleeson. Copy attached.

Upcoming Training:

Vital Signs Academy is ongoing.

Vital Signs Conference will be held virtually this year with an emphasis on the non core mandatory classes.

There will be a Spring EMT Class at Gouverneur Rescue sponsored by Jefferson County.

Didactic hours will be virtual on Mondays and Thursdays. Skill sessions will be held at various locations.

Airport MCI drill will be held at Ogdensburg Airport on October 22.

The Elizabethtown Paramedic program will be holding sessions in Potsdam.

Committee Reports:

Executive Committee - No report

Communications - No report

Legislative - Proposed state legislation - Tax breaks during COVID pandemic, direct pay by insurance companies, COVID relief, Community Paramedicine bill. No action reported

Personnel - Discussion regarding Bylaws. Looking for suggestions for new members of this Board. Interested in community members of influence with input from the county. Looking for actual consumers for those seats. Discussion regarding the number of members allowed on this Board by state law and the county, as well as the membership categories assigned. No action was taken.

Dispatch Committee - No report.

Agencies/Hospitals - No report.

Old Business:

Matt Denner provided an update on the new towers being constructed.

Matt Denner provided new Fire Rehab forms. The new policy is out. He will have it sent to all agencies.

COVID-19:

SLC reports a slight increase in the number of cases. Currently no hospitalizations.

Agencies are advised to prepare for a second wave by securing a 90 day supply of PPP.

The reopening plan is available on the state website.

Make sure that your facility has the proper signage and floor markings.

Face masks are required if two people are together in the front, or patient compartment of the ambulance.

Warned that the state is enforcing violations state wide.

Providers and agencies face a possible fine of up to \$1,000 for violations.

New Business:

Committee Assignments

Communications:

James Barr

Kevin Wells

Dr. Ryan Coates

Personnel:

Aaron Johnson

Chris Valex

Carol Muench

Storm Cilley

Legislative:

Jay Moore

James Blackburn

Nick Wildey

PIER (Public Information Educations Relations):

Don Thompson

Chris Towler

Rita Curran

Discussion regarding public relations and use of social media. Advised to use discretion and caution in posting. No action taken.

County EMS Awards are currently being solicited.

Discussion regarding difficulty that agencies are having filling positons.

Discussion of the NYS Workforce Survey. The Office of Emergency Services will send it out.

Motion to adjourn by Carol Muench, Seconded by Ann Smith.

Meeting adjourned at 2051 hours.

St. Lawrence County

Year To Date Report for 2020

January 1st – November 16th 2020

Colleen Gleeson
Account Executive

Requests/Transports/Cancelled

YTD Totals For 2020			
Requesting Agency	Requests	Transports Completed	Cancelled
St. Lawrence County 911	75	27	48
Canton Potsdam Hospital	158	103	55
Claxton Hepburn Medical Center	44	29	15
Clifton Fine Hospital	2	2	0
Gouverneur Hospital	25	14	11
Massena Hospital	67	39	28
Misc. 911 Requests	2	2	0
TOTALS	373	216	157

Requests by County

Q3 Totals 2020			
Referring Agencies	Requests	Transports Completed	Cancelled
Jefferson County 911/Hospitals	227	94	133
Lewis County 911/Hospitals	44	24	20
St. Lawrence County 911/ Hospitals	33	12	21
TOTAL	304	130	174

North Country Clearinghouse

3nd Quarterly Report for 2020

July 1st – September 30th 2020

Colleen Gleeson
Account Executive

Requests

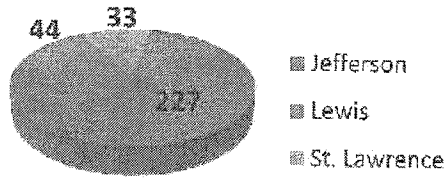

Transports

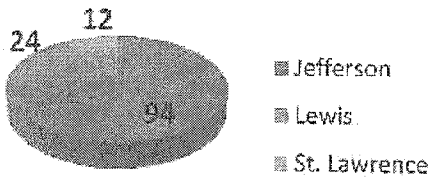

Cancellations

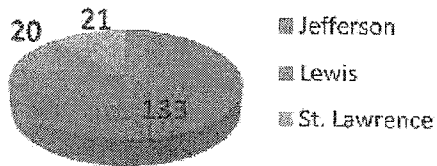

Requests by Company Aircraft

Q3 Totals 2020			
Responding Aircraft	Requests	Completed Transports	Cancel/Miss
LifeNet 7-10 Watertown	267	105	162
LifeNet 7-9 Potsdam	6	2	4
LifeNet 7-12	8	6	2
LifeNet 7-13	1	0	1
LifeNet 7-2	1	1	0
LifeNet 7-1	1	1	0
Onondaga Co Air One	1	0	1
Mercy Flight Rome	18	14	4
Mercy Flight Marcellus	0	0	0
Mercy Flight Canandaigua	1	1	0
North Country Life Flight	0	0	0
Total	304	130	174



ST. LAWRENCE COUNTY
EMERGENCY MEDICAL SERVICES
ADVISORY BOARD

2021 Proposed Meetings

- January 26, 2021
- March 23, 2021
- May 25, 2021
- September 28, 2021
- November ~~23, 2021~~ *30, 2021*

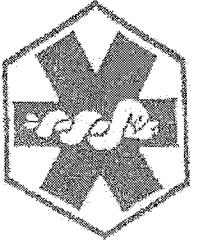

**ST. LAWRENCE COUNTY
EMERGENCY MEDICAL SERVICES
ADVISORY BOARD**

St. Lawrence County EMS Advisory Board
November 17, 2020

Name	Signature	Address and email changes, if any	Home/Cell Phone	
Ann Smith	<input checked="" type="checkbox"/>			R
Phyllis McDougall				C
<i>Open</i> <i>Christina Taylor</i>	<input checked="" type="checkbox"/>			R
Richard McDougall				R
Nicholas Wildey	<input checked="" type="checkbox"/>			X
Carol Muench	<input checked="" type="checkbox"/>			N
James Blackburn	<i>by</i>			R
Christopher Velez				X
Aaron Johnson	<input checked="" type="checkbox"/>			R

Name	Signature	Address and Email change if any	Home/Cell Phone	
Clifton Fine- Chelsea Snyder- Dennis				H
Gouverneur- Jay Moore	EM			H
Ex-Officio Rita Curran				
Jonathan Mitchell	✓			
Guests Life Net				
Colin Green	✓	Awards		
Doug Bork	✓	Papers	Asst. Sec	
Theodore Justice	✓	R		
Dawn McQuinn	✓	SEC Award / Paper		
Arlene Simpson				

Request by Aircraft

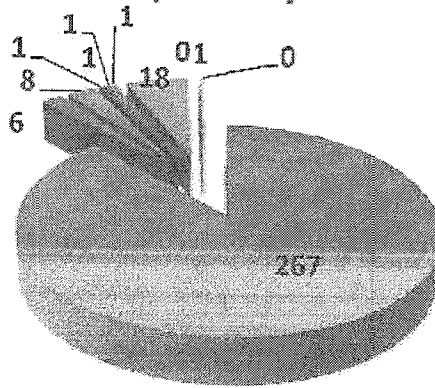

- LN 7-10
- LN 7-9
- LN 7-12
- LN 7-13
- LN 7-2
- LN 7-1
- Onon. Air One
- MF Rome
- MF Marcellus
- MF Can.
- NCLF

Transport by Aircraft

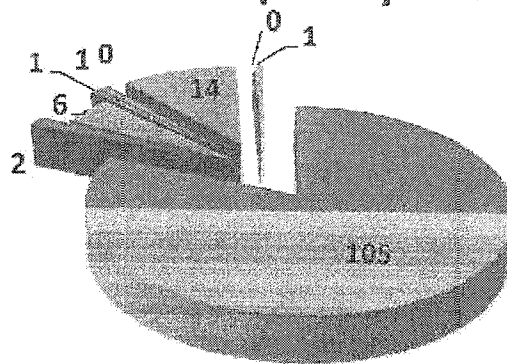

- LN 7-10
- LN 7-9
- LN 7-12
- LN 7-13
- LN 7-2
- LN 7-1
- Onon Air One
- MF Rome
- MF Marcellus
- MF Can
- NCLF

Cancellation by Aircraft

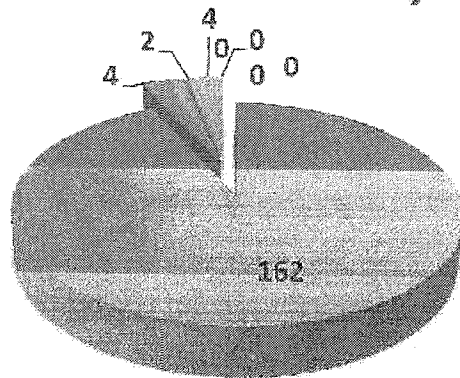

- LN 7-10
- LN 7-9
- LN 7-12
- LN 7-13
- LN 7-2
- LN 7-1
- Onon Air one
- MF Rome
- MF Marcellus
- MF Can
- NCLF

Name	Signature	Address and Email change if any	Home/Cell Phone	
Kevin Wells	KW			L
Donald Thompson				R
R. Storm Cilley	✓			R
Dr. Coates				M
Juhanne Sciorra-CHWC				H
Open <i>Doug Barr</i>	✓			X
James Barr	JB			R
Mark Deavers	✓			R
Open				R
Open				C
Open				X
MMH- Open				H
CPH- Tammy Sykes	TS			H